

Dura Deck Type 295 – Warranty Approved Install Instructions

Material Composition

Dura Deck is produced by extruding a unique composition of reclaimed wood, high density polyethylene and a number of engineered stabilisers such as UV inhibitors and mould preventers. This creates our unique products, which can be used internally or more commonly outdoors. Dura Deck provides outstanding weather-proof performance and endurance even in extreme weather conditions.

The combination of high strength and beautiful wood appearance is created as a result of achieving the optimal ratio of wood fibre to plastic resin combined with exacting temperature and speed control during the manufacturing process.

Dura Deck has been put subjected to rigorous testing both in the laboratory and in practical outdoor exposure tests in 3 continents. The testing has taken place since 2007 and has been carried out in tropical conditions across a wide range of extreme temperatures and humidities. These tests have provided outstanding results and allow us to supply a product which performs in all weather conditions retaining optimum strength whilst looking like real timber but with all of the benefits of being an engineered material.

Installation & Fixing Guidelines

Our product has been designed for its simplicity and ease of installation however to ensure long term performance we recommend that a professional trade person carries out the installation. The installation **MUST** be carried out in accordance with our instructions. Failure to use our instructions and/or failure to use our fixing and trim systems will invalidate the warranty for the product. Install sites are always different; however, using our instructions will provide the highest chance of achieving a high quality, professional finish every time. Most installers will find this process very similar to the installation of a real wood deck. However, there may be a few key areas where care must be taken with specific aspects.

Please remember that the installation method recommended by Dura Composites may not cover every installation scenario that you may encounter. That is why a professional should be used in order to adapt the methodology for specific situations. Each installation is unique in its performance requirements, and therefore the installation is the sole responsibility of the installer. Dura Composites recommends that all designs be reviewed by a licensed architect, engineer or local building official before installation. Make sure your plans meet local building codes before you begin the installation.

1. Safety First

- Keep children away from the work area until the job has been completed and tools have been stored safely.
- Refer to operators manuals for all power tools safety guides
- When handling WPC timber always wear gloves and eye protection and work in a well ventilated area.
- Do not burn WPC off-cuts. Dispose of them safely as refuse.
- Wear goggles when pressure washing or scrubbing.
- Preparation - Do not expose planks to direct sunlight when storing. Weathering may lighten or darken coloured cladding. However, this will stabilise after approx 6 months.

Important Notes

- Dura Deck is **NOT** intended for use as columns, support posts, beams, joist stringers or other primary load-bearing members.
- Dura Deck must be supported by a code-compliant substructure.
- While Dura Deck products are great for deck re-planking (removing old deck surface planks and installing Dura Deck on code-compliant substructure), Dura Deck planks **CANNOT** be installed on top of existing deck planks.

2. Fixings

All Dura Deck products should be fixed or secured using Dura Composites approved products suited to the job. The raw material and the type of coating used to protect these from corrosion is vital. This is why Dura Composites recommend the use of stainless steel fixings. Our price list give details of our warranty approved screws and clips, please ask for details. We do not in any circumstance recommend the boards are fixed through the board surface, whether by nails or screws. The use of our special below surface fixing clips obviates the need for any through-surface fixings.

3. Site Preparation

The site must be free draining or of a gradient of 1 in 40 to allow water "run off". If the area you have chosen is grass you can either remove the turf or cover it with a weed barrier, as long as its edges are tucked deep into the soil using an edging spade. If your deck is to be at ground level then the removal of 100mm of soil is recommended. Replace the topsoil with 100mm of compacted gravel or hardcore. This provides a very solid but free draining site on to which you can build the sub-frame. On any over site it is essential that you lay a weed barrier . It is advisable to cover the top of the weed barrier with a light stopping layer of pea shingle. You could use strategically positioned patio slabs instead of compacted gravel or hardcore, but we do not recommended this as they tend to settle causing problems with your deck later.

4. Sub Frame

A sub-frame allowing a minimum of 100mm air-space between the Dura Deck planks and the ground or substrate is essential to allow sufficient air-flow to prevent the build-up of moisture

- The sub frame can be built from timber, GRP or Steel whichever method is preferred
- WPC bearers can be supplied in 102mm depths to suit all applications. 53mm & 44mm depth WPC bearers can be used for dry, ventilated situations
- The maximum span between supporting joists depend on the specific Dura Deck product
- You should refer to the Load & Deflection Data Table below to determine the maximum span

Most decks (other than ground level) use a post and beam construction. The support posts (normally placed at no more than 1800mm) centers sit in or on concrete footings, the later using a metal connector / shoe. Please refer to the Load & Deflection Data Table below to select appropriate spacing's for joists depending on the type of Dura Deck used.

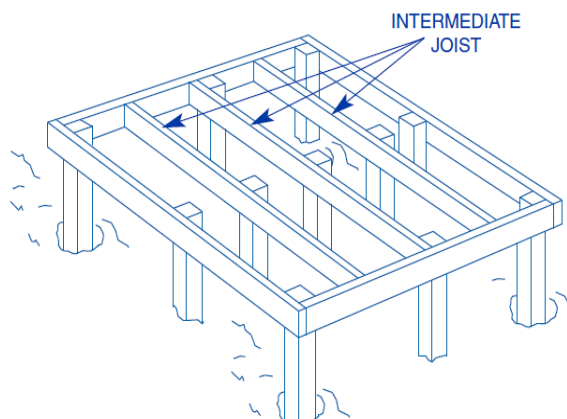

5. Style of Deck

It is essential to plan your deck in advance and this is best done on paper. You cannot simply make up a bearer frame of any size and then expect the deck boards to fit with the required gaps between them without having to reduce the width of boards to fit.

Carefully decide on the location and the use of your deck. Decide on whether you want a sunny or shaded location and importantly whether privacy is a requirement. Decks in permanent shade could be affected by damp and consequent algae growth.

Be aware that very large decks and raised decks may require planning permission. Raised Decks should not be built with the deck level more than 600mm above ground level without specialist advice. When installing posts or leveling take special care not to damaged underground pipes or drainage and do not obstruct manhole covers or other services.

SOME DECK-BOARD LAYOUTS

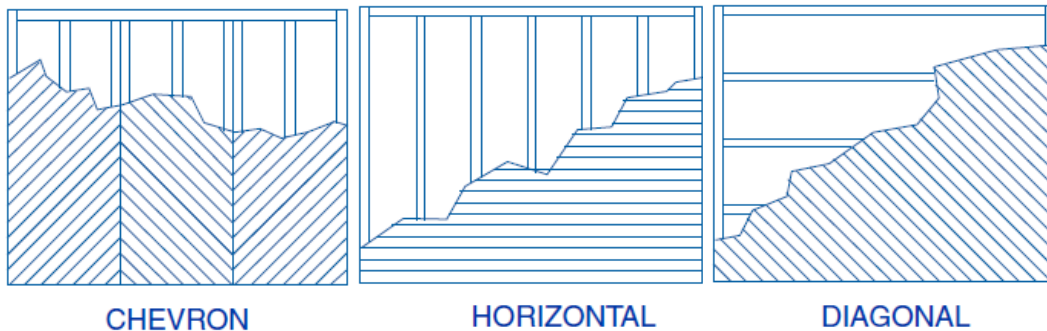

Dura Deck Pedestrian Load Span Chart plus Load & Deflection Data (Europe)					
Plank (mm)	90° Span	45° Span	30° Span	Concentrated Line Load Kg/m @ 1% deflection	UDL Kg/M2 @ 1% Deflection
Type 295	600mm	550mm	500mm	287	2296
Type 225	750mm	700mm	650mm	298	2490
Type 146	400mm	350mm	300mm	289	2312

Dura Deck Pedestrian Load Span Chart plus Load & Deflection Data (Middle East)

Plank (mm)	90° Span	45° Span	30° Span	Concentrated Line Load Kg/m @ 1% deflection	UDL Kg/M2 @ 1% Deflection
Type 295	550mm	500mm	450mm	287	2296
Type 225	700mm	650mm	600mm	298	2490
Type 146	350mm	300mm	250mm	289	2312

Please note that it will be necessary to reduce the joist span if the loading exceed those stated above. Always contact Dura Composites if you are unsure.

6. Gapping - Allowing for Expansion (and Contraction)

Dura Deck planks will expand and contract with changes in temperature. Expansion and contraction are most significant where extreme temperature changes occur. Fastening the deck planks according to the gapping requirements noted in the table below accommodates for this movement.

Gapping Requirements

- Allow **5mm** minimum gap where the planking meets any adjoining structure or post
- Follow these butt joint gapping guidelines for all Dura Deck planks to suit your region

Install Temp Degree C	UK Gapping Requirement (mm)					Middle East Gapping Requirement (mm)					Eastern Europe Gapping Requirement (mm)				
	1m	2m	3m	4m	5m	1m	2m	3m	4m	5m	1m	2m	3m	4m	5m
-25											2.75	5.50	8.25	11.00	11.00
-20											2.5	5.00	7.50	10.00	10.00
-15	2.50	5.00	7.50	10.00	12.50						2.5	5.00	7.50	10.00	10.00
-10	2.25	4.50	6.75	9.00	11.25						2.25	4.50	6.75	9.00	9.00
-5	2.00	4.00	6.00	8.00	10.00						2	4.00	6.00	8.00	8.00
0	1.75	3.50	5.25	7.00	8.75						1.75	3.50	5.25	7.00	7.00
5	1.75	3.50	5.25	7.00	8.75						1.75	3.50	5.25	7.00	7.00
10	1.50	3.00	4.50	6.00	7.50	2.50	5.00	7.50	10.00	12.50	1.50	3.00	4.50	6.00	6.00
15	1.25	2.50	3.75	5.00	6.25	2.25	4.50	6.75	9.00	11.25	1.25	2.50	3.75	5.00	5.00
20	1.25	2.50	3.75	5.00	6.25	2.00	4.00	6.00	8.00	10.00	1.25	2.50	3.75	5.00	5.00
25	1.00	2.00	3.00	4.00	5.00	1.75	3.50	5.25	7.00	8.75	1.00	2.00	3.00	4.00	4.00
30	1.00	1.50	2.25	3.00	3.75	1.50	3.00	4.50	6.00	7.50	1.00	1.50	2.25	3.00	3.75
35	1.00	1.50	2.25	3.00	3.75	1.25	2.50	3.75	5.00	6.25	1.00	1.50	2.25	3.00	3.75
40						1.00	2.00	3.00	4.00	5.00					
45						1.00	2.00	3.00	4.00	5.00					
50						1.00	1.50	2.25	3.00	3.75					
55															

7. Laying the Deck

Once you have decided on the substructure layout/deck plan & are happy that all the levels and steps are carefully worked out, the decking process can begin.

The installation process and use of fixings for Dura Deck products is very similar throughout the range. Key things to remember are:

- Always use a deck frame that allows a minimum of at least **100mm** clear air-flow between the ground and the plank
- Always use Dura Deck approved fixings to avoid fixing directly through plank (both start-stop clips and standard fixing clips)
- If using Dura Deck end caps, always use Dura Composites supplied adhesive
- Stagger your joints
- Leave enough clearance for expansion (as per table)
- Always support the end of a plank on a bearer
- If mitering planks make sure there is sufficient support running underneath

Deck Laying Process

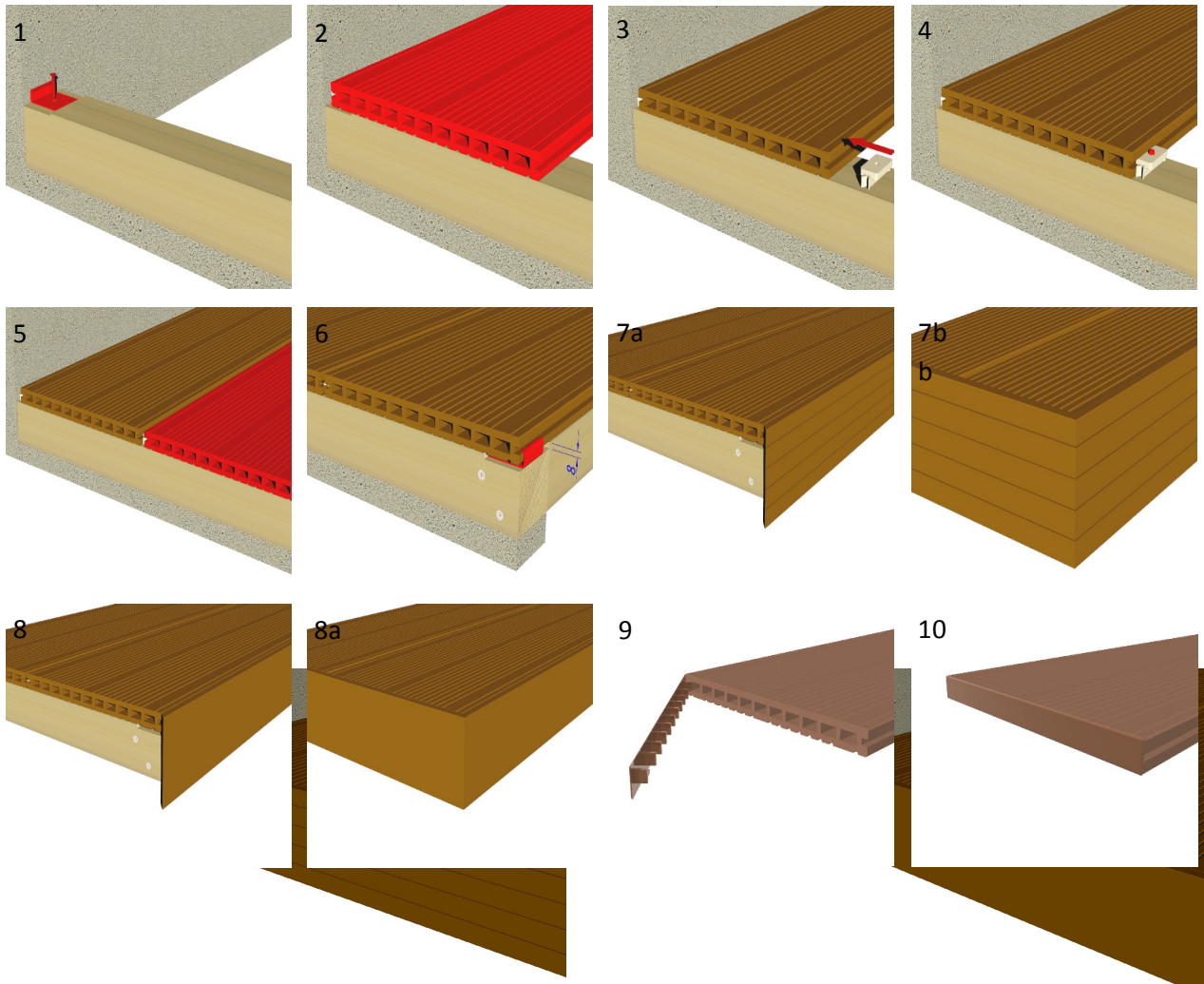

8. Cutting & Fixing Tool Options

Chop saw

(Any wood cutting blade can be used, although Fine Teeth are highly recommended)

- Used for simple straight cuts
- Ideal for cutting obtuse and acute angles
- Perfect for cutting mitres



Jigsaw (Any Bosch wood blades can be used)

- Used for simple straight cuts, radius edges and for intricate shapes
- Useful for notching out sections
- A proficient Jigsaw operator is capable of absolute precision



Circular Saw

(Any wood cutting blade can be used, although Fine Teeth are highly recommended)

- For cuts that exceed 1 metre and provides a perfect straight line cut
- Usually quicker than using a jigsaw but limited to cuts in one direction at a time
- Can be sourced from Dewalt, Bosch or Hilti etc
- A proficient Circular Saw operator is capable of absolute precision



Drills

- Used for creating clearance holes using appropriate sized drill bit depending on the size of the fixing (clearance hole should be big enough for the fixing to pass through the object it is fixing)
- Used for screwing fixings through clearance holes to firmly secure object
- Drill can also be used with attachments such as Hex (Allen) key tool or a socket to the correct diameter of the fixing to enable rapid tightening of the fixings
- There are a number of power tool manufacturers such as Dewalt, Bosch or Hilti
- We regularly use battery powered tools on installations in the UK where ext this may be a suitable option for environments out of range of a power sup
- It is essential to keep a large stock of the appropriate blades to suit each p

